



WEST TEMPERATURE  
& PROCESS CONTROL



# WEST CONTROLLERS

## 6100+, 8100+ & 4100+ Controllers

### Features

- 1/16 DIN (48 x 48 x 110mm), 1/8 DIN (96 x 48 x 100mm) and 1/4 DIN (96 x 96 x 100mm) formats (HxWxD)
- Ideal for general industrial applications
- Universal input for thermocouple, PT100, mV, V and mA sensors
- Up to three outputs
- Flexible options for RS485, remote setpoint, digital inputs and transmitter power supply
- Programming port for fast configuration using FTP software



The + series of controllers are used in a broad range of temperature and process control applications due to their built-in versatility and ease-of-use.

Input and output options include relay, SSR, transmitter power supply, linear remote setpoint and digital.

Control functionality includes remote and dual setpoint options, heat/cool control and setpoint ramping.

### Selection Guide

<p>6100 6100+ 8100 8100+ 4100 4100+</p> <p><b>P 6100</b></p>	<p><b>Option Slot 1</b></p> <p>0 Not fitted 1 Relay 2 DC for SSR 7 DC linear 8 Transmitter power supply</p>	<p><b>Option Slot 2</b></p> <p>0 Not fitted 1 Relay 2 DC for SSR 7 DC linear 8 Triac</p>	<p><b>Option Slot 3</b></p> <p>0 Not fitted 1 Relay 2 DC for SSR 7 DC linear 8 Transmitter power supply</p>	<p><b>Option Slot A</b></p> <p>0 Not fitted 1 RS485 communications 2 Digital input 3 Remote setpoint input (basic)</p>	<p><b>Display Colour</b></p> <p>0 Red upper &amp; lower 1 Green upper &amp; lower 2 Red upper, green lower 3 Green upper, red lower</p>	<p><b>Option Slot B</b></p> <p>0 Not fitted R Remote setpoint input (full)</p>	<p><b>Power Supply</b></p> <p>0 100-240V AC 2 24-28V AC or DC</p>
--	---	--	---	--	---	--	---

## 6170+, 8170+ & 4170+ Controllers

### Features

- 1/16 DIN (48 x 48 x 110mm), 1/8 DIN (96 x 48 x 100mm) and 1/4 DIN (96 x 96 x 100mm) formats (HxWxD)
- Universal input for thermocouple, PT100, mV, V and mA sensors
- Valve position indication
- Auto or manual tuning
- Process & loop alarms
- Remote/dual setpoint
- Modbus communications - RS485



The 6170+, 8170+ and 4170+ have been designed specifically for open loop valve motor drive (VMD) applications.

They feature an improved + series interface and greater field flexibility.

A unique VMD tuning algorithm continuously monitors the process to provide stable control at all times.

### Selection Guide

<p>6170 6170+ 8170 8170+ 4170 4170+</p> <p><b>P 6170</b></p>	<p><b>Option Slot 1</b></p> <p>0 Not fitted 1 Relay 2 DC for SSR 7 DC linear 8 Triac</p>	<p><b>Option Slot 2</b></p> <p>0 Not fitted 1 Relay 2 DC for SSR 7 DC linear 9 Dual relay</p>	<p><b>Option Slot 3</b></p> <p>0 Not fitted 1 Relay 2 DC for SSR 7 DC linear 8 Transmitter power supply</p>	<p><b>Option Slot A</b></p> <p>0 Not fitted 1 RS485 communications 2 Digital input 3 Auxiliary input (basic)</p>	<p><b>Display Colour</b></p> <p>0 Red upper &amp; lower 1 Green upper &amp; lower 2 Red upper, green lower 3 Green upper, red lower</p>	<p><b>Power Supply</b></p> <p>0 100-240V AC 2 24-28V AC or DC</p>
--	--	---	---	--	---	---





# WEST LIMIT CONTROLLERS & INDICATORS

## 6700+, 8700+ & 4700+ Limit Controllers

### Features

- 1/16 DIN (48 x 48 x 110mm), 1/8 DIN (96 x 48 x 100mm) and 1/4 DIN (96 x 96 x 100mm) formats (HxWxD)
- Universal input for thermocouple, PT100, mV, V and mA sensors
- Modbus communications across the range (as well as West ASCII)
- Configuration via PC
- Up to three outputs
- Improved, easy-to-use HMI
- FM approval



Limit controllers provide a latched relay output which is activated when process parameters either exceed or fall below the desired value, providing a fail safe cut-off which has to then be reset before the process can continue. LED indication shows when limits have been exceeded and when the relay is latched out.

With a full range of universal sensor input options, the + series range provide a valuable safety control element for most systems.

### Selection Guide

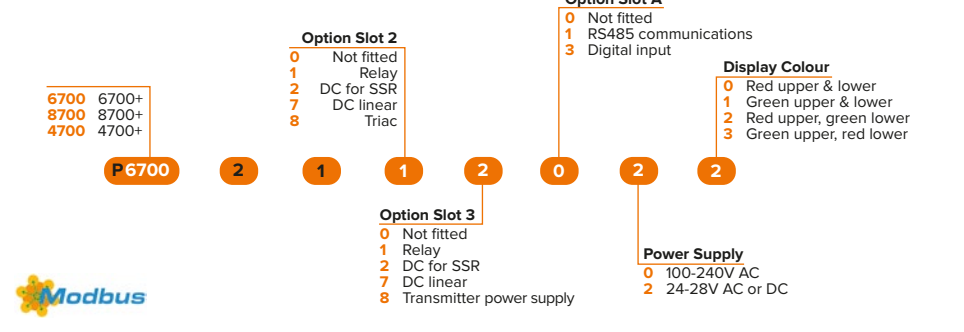

## 6010+ & 8010+ Indicators

### Features

- 1/16 DIN (48 x 48 x 100mm) and 1/8 DIN (horizontal) (48 x 96 x 110mm) formats (HxWxD)
- Universal input for thermocouple, PT100, mV, V and mA sensors
- Output options for SSR driver, triac, relay and linear
- Optional alarms are selectable as latching or non-latching outputs
- PC Configurator with easy to use "wizard" suits both novice and experienced users
- Multi-point scaling and tare features included as standard
- Modbus and ASCII communications
- Red/green single-line 4-digit display
- Up to 4 outputs



The 6010+ and 8010+ digital panel process indicators are designed for optimal ease of use in a wide variety of temperature and related process applications.

Output options allow for PV retransmission or transmitter power supply and up to 4 alarm relays (latching or non-latching).

### Selection Guide

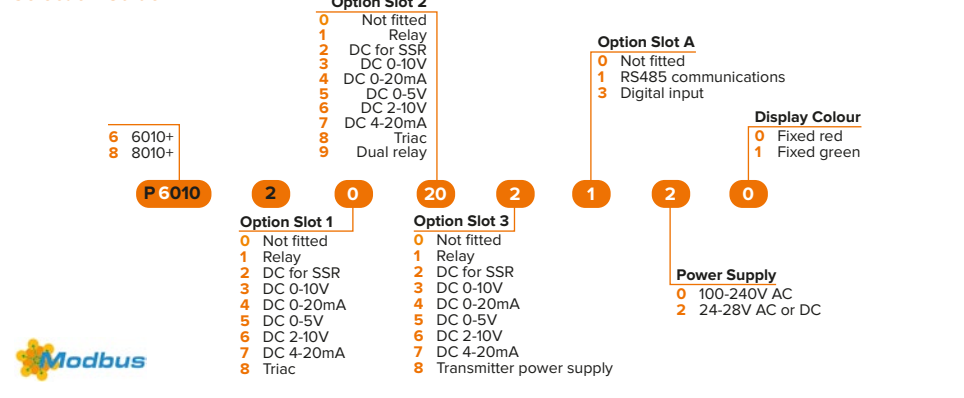



# WEST 1/16 DIN PROGRAMMABLE CONTROLLERS

## Pro-16 Advanced Process Controller

### Features

- 1/16 DIN (48 x 48 x 118mm) format (HxWxD)
- 1 universal input + 1 optional
- Customer specific linearisation for sensor
- Up to 4 digital inputs
- Heater or remote setpoint current input
- Up to 6 outputs - relay, logic, SSR, linear DC
- Transmitter power supply
- 16 profiles x 16 segment

A compact, fully featured controller for demanding applications. Pro-16 is the only controller of its size, flexible with up to 6 outputs, 2 digital inputs, a remote setpoint input, RS485 communications and linked to best in class BlueControl® software.

The Pro-16 offers many integrated features for unrivalled performance such as two PID sets to ensure reliable control over a wide setpoint range and separate PID for heat and cool strategies for optimised control and stability. Extensive flexibility is offered with 1 universal input and 1 optional, up to 4 digital inputs, 6 outputs and an inbuilt profile.



### Selection Guide

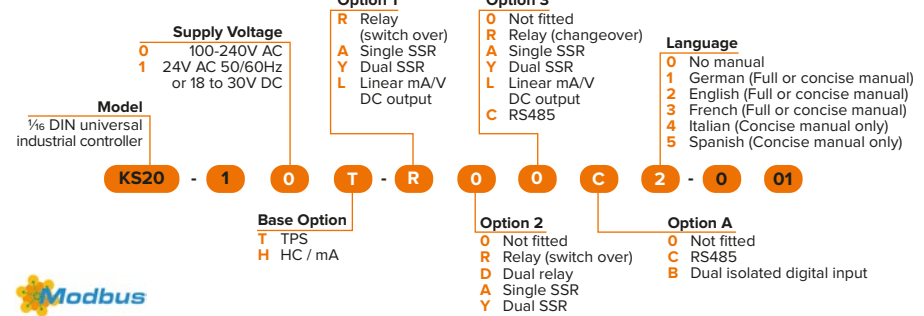

## N6400 Programmable Process Controller

### Features

- 1/16 DIN (48 x 48 x 110mm) format (HxWxD)
- Fast and accurate control via raPID fuzzy logic
- 'Auto hold' facility, remote run hold, event output, power failure recovery and guaranteed soak
- 4 programs with 16 free-form segments
- Program ramps in rate or time mode
- Delayed start
- RS485 Modbus comms

The N6400 is a powerful, single loop programmable controller for complex processes. It offers profiling capability with 4 programs each of 16 free format segments. The N6400 is an easy-to-use controller, which benefits from an informative display providing maximum process information at a glance. A dedicated configuration port allows configuration directly from a PC and allows for the development, transfer and storage of recipes by dedicated software.



### Selection Guide

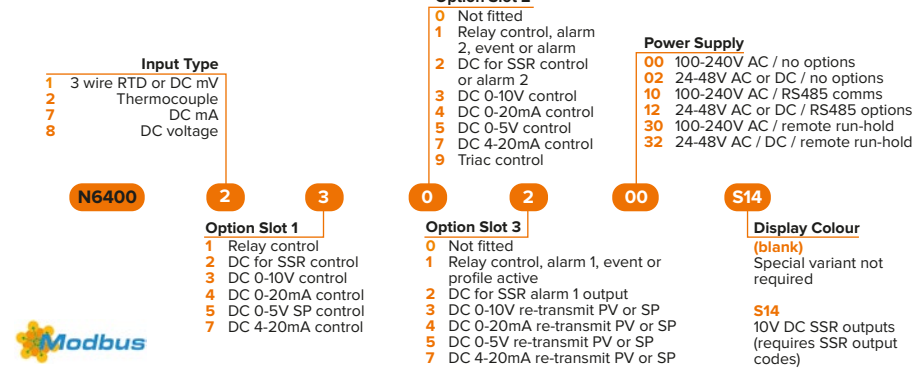



# WEST MULTI-LOOP TEMPERATURE CONTROLLER

## Pro-EC44 Single or Dual Loop Controller

### Features

- ¼ DIN (96 x 96 x 117mm) format (HxWxD)
- Single or two loop
- Supports cascade and ratio control
- Graphical / text display (red/green backlit LCD)
- Profiler 255 segments shared by up to 64 program
- USB configuration and data access
- Modbus RS485 or Modbus TCP Ethernet
- Up to 5 PID sets
- Gain scheduling
- Datalogger with real-time clock

Pro-EC44 is designed to simplify user setup, step by step configuration with a wizard saves needing to work through several menus for initial configuration of common settings. A logical menu structure for intuitive navigation allows fast changes and updates to individual settings. Alternatively Pro-EC44 can be set up through the BlueControl® PC software.



### Quick access to important product information

Stepping through several pages to get important process information can be time consuming and lead to inefficiency. The Pro-EC44 pages have been carefully structured to show users the important process information on a single page, minimising the steps to access data and settings. A colour change green/red LED backlight provides easily recognisable alarm indication to improve response times in taking corrective action.

### Configure controllers without the need for an expensive PC

PCs are often vulnerable in the harsh environments of production and process plants. Pro-EC44 configuration files can be downloaded to a controller using a flash memory stick via the front USB port allowing for fast programming with no risk to expensive equipment. Settings can also be read via the USB port to clone additional devices or configure a replacement.

### Reduce the number of controller spares needed on your production plant

Many production plants need several types of controller to get the control capability needed for different aspects of a manufacturing process. Pro-EC44 is a single controller meeting all your needs with many features to ensure good control performance.

### Selection Guide

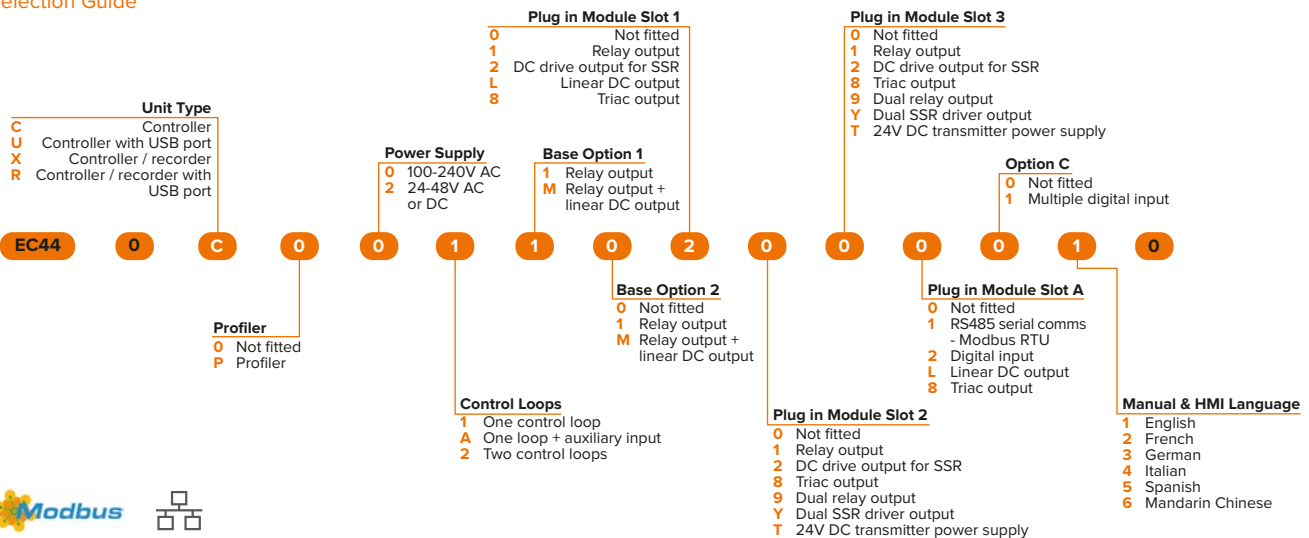





# WEST DIN-RAIL MOUNTED DEVICES

## MAXVU Rail - DIN-rail Temperature Controller / Transmitter & Limiter

MAXVU Rail is a compact DIN rail mount temperature controller/transmitter and limiter for general industrial and scientific equipment requiring a reduced back panel footprint, centralised control or minimal front panel components.

The slim 22.5mm width behind panel devices are quick to integrate in a system and easy to set-up, the affordable product family offers:

- PID controller for stable and efficient temperature and process control
- Transmitter function for monitoring and data collection of process measurements
- FM approved limit device for machine protection

### Reduce setup time

#### Clear text/graphic display

MAXVU Rail incorporates the latest Oled technology display for high contrast text/graphic display with a wide viewing angle, easily visible to configure in bright sunlight or a dark control panel.

#### Short set up menu

MAXVU Rail has been specially designed for ease-of-use through a fast setup menu accessed from the front keypad.

- Includes the most common parameter settings
- Other parameters still available through the full menu
- Prioritised parameter options, default is the most common option with second most common next on the list

#### PC Configuration software

Alternatively, fast configuration of instruments can be achieved with the MAXVU software via the controller's front access configuration port.

- Logical menu driven interface
- Graphical setup wizard with informative help panel
- Tables with drop down menus
- Save configuration files
- Print report of controller settings

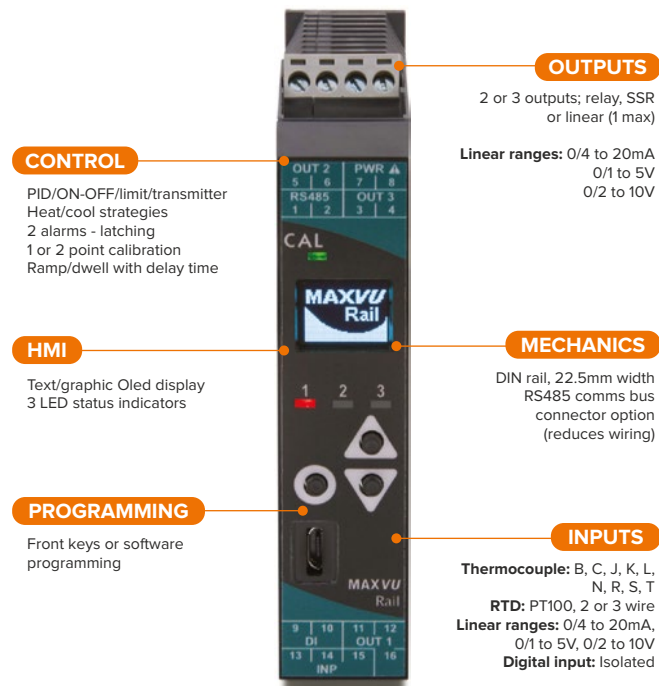

### MAXVU Rail Controller / Transmitter Selection Guide

**Modbus**

Variant	Out 1	Out 2	Out 3
0 Standard	Z A 0 C/O Relay	SSR	None
E Extrusion	Z R 0 C/O Relay	Relay	None
	A A 0 SSR	SSR	None
	Z A R C/O Relay	SSR	Relay
	Z R R C/O Relay	Relay	Relay
	A A R SSR	SSR	Relay
	Z A L C/O Relay	SSR	Linear
	Z R L C/O Relay	Relay	Linear
	A A L SSR	SSR	Linear

**MVR 1 0 M Z A 0 0 5 1 U0**

**Digital Input**  
 1 Isolated

**Supply Voltage**  
 M 110 to 240V AC  
 L 24V AC / DC

**Option Slot 2**  
 0 Not fitted  
 C RS485 communications

### MAXVU Rail Limiter Selection Guide

**Modbus**

Variant	Out 1	Out 2	Out 3
0 Standard	Z R 0 C/O Relay	Relay	None
E Extrusion	Z R R C/O Relay	Relay	None
	Z A L C/O Relay	SSR	Linear
	Z R L C/O Relay	Relay	Linear
	Z A 0 C/O Relay	SSR	None
	Z A R C/O Relay	SSR	Linear

**MVR 1 T M Z A 0 0 5 1 U0**

**Digital Input**  
 1 Isolated

**Supply Voltage**  
 M 110 to 240V AC  
 L 24V AC / DC

**Option Slot 2**  
 0 Not fitted  
 C RS485 communications



# WEST BLUECONTROL SOFTWARE

## BlueControl Software

### Features

- Fast configuration
- Reliable copying
- Settings are tested with the integrated simulation
- Archiving and documentation
- Reduced commissioning time
- Free download

BlueControl® is a powerful tool for setting parameters, simulation, commissioning, and diagnosing PMA's BluePort® devices as well as the KS80 controller range, rail line equipment, and KS vario.

### Description

The primary function of BlueControl® is parametrising of control equipment with the assistance of plain texts, a clear structure, and online help, thus enabling quickly and safely. Hereby, all settings can be edited, copied, and saved. If BlueControl® is linked with an active device (online mode), the most important process data and settings of the connected device can be monitored and changed, and the trend function also permits them to be recorded. The display is in real-time.

A completely risk-free procedure is provided by the detailed device and process simulation, primarily for testing control functions before commissioning, or for training purposes. This feature also permits the simulation of comprehensive functions and complex devices, without having to connect the device or process signals to the PC.

Moreover, special functions are offered for numerous device types and families. For the BluePort® range, the front panel operation and display can be modified extensively. For devices with the PROFIBUS-DP option, the variable bus accesses are defined via BlueControl®.

The program editor provided in the expert version greatly simplifies the adjustments necessary for devices of the programmer type. BlueControl® uses established Microsoft Windows operating standards as well as the familiar operating elements and menu structures of Microsoft Office programs.

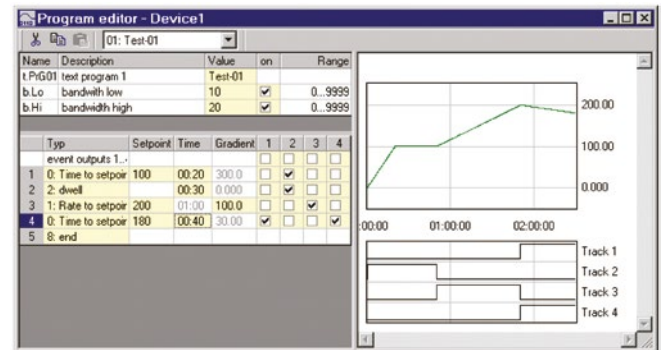
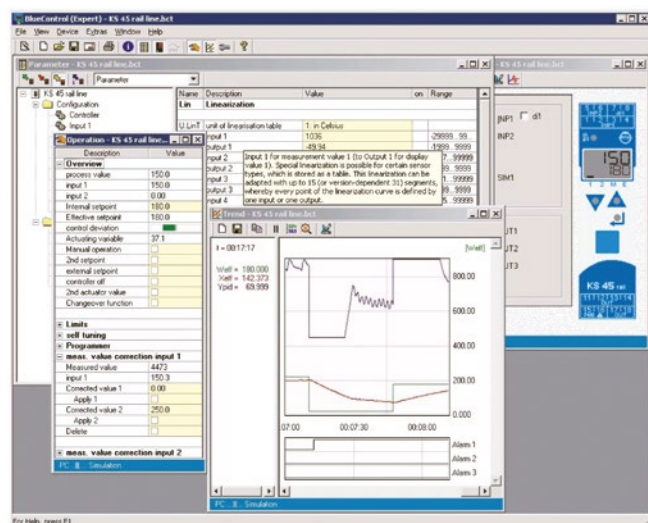

### Wizard for controller tuning

The Wizard for controller tuning provides a quick entry into the use of BlueControl®. The most important adjustment options are summarised on just a few display screens.

### Upload / Download

Upload: transferring (writing) the data from the PC or simulation into the external device. Download: fetching (reading) the data from the external device into the PC or simulation.

### Simulation

The built-in device simulation permits the front operating elements as well as the inputs/outputs to be displayed. Here, the simulation takes the input scaling into account, as well as switching via digital inputs, device behaviour in case of a fault, and adjusted limit values. The adjustable process simulation is connected automatically to the outputs of the simulated device. The process simulator permits various processes to be represented, using all conventional models.

### Online operation

The 'connect' mode provides the possibility to monitor and adjust the most important process values. Setpoints can be defined, and switchovers can be triggered. The self-tuning function can be started and the result is displayed. The finishing touch is provided by the trend graphics for device and simulation, enabling the quality of the loop to be assessed at a glance.

### Trend recording

Trend recording permits data from the simulation or from the device to be displayed graphically. The trend display is in real-time. The display contains a time axis (relative = starting from the time of connection, or absolute = historical) and the measured values in the form of numeric data. Analogue values are displayed as curves, and digital data are shown in the format of a logic analyser.

Trend functions are: zoom, pause, measurement scale for precise evaluation, scaling and inscription of the Y axes, copying into the clipboard, saving in the Excel-compatible CSV format, opening of stored trends.

### Communication via Modbus, Profibus, or Ethernet

For this, the device offers an interface in the front panel and at the rear. Devices are connected to the PC via:

- COM port (COM1...COM8)
- Profibus interface (PROFIBUS 1...4) via a Siemens or Hilscher card
- Ethernet interface



# WEST THYRISTORS

## Relay CL - 1PH Thyristor Power Controller

### Features

- Load type: normal resistance, infrared long, short and medium waveform, silicon carbide and cold resistance coupled with transformer
- Inputs: 0-10V dc, 4-20mA, 10kpot, SSR, RS485
- Firing mode: burst firing, single cycle, soft start + phase angle and delayed triggering
- Operating temperature: 0 to 40°C without derating
- Control mode: voltage, Vxl power and current I & I2
- RS485 port. RTU Modbus protocol
- Comply with EMC

Single-phase thyristor power controller for complex load requirements including feedback and current limit.



### Selection Guide

Current		
035	35A	180 180A
040	40A	210 210A
060	60A	280 280A
090	90A	400 400A
120	120A	500 500A
150	150A	600 600A
		700 700A

Input	
V	0-10V DC
A	4-20mA
K	10kpot
R	RS 485

Control Mode	
O	Open Loop
U	Voltage feed back V
W	Power feed back Vxl
Q	Voltage squared V2
I	Current feed back I

Fuse & Option	
Y	For units <=40 fuse + fuse holder + CT standard
H	Fuse + fuse holder + CT + HB with screw terminal
Y	For units > 40A fixed fuse + CT
H	Fixed fuse + CT + HB

Approvals	
0	CE EMC for European market

**RCL**

**035**

**4**

**1**

**V**

**D**

**O**

**Y**

**0**

**0**

**2**

**1**

#### Max Voltage

- 4 480V
- 6 600V
- 7 690V (1)

#### Voltage Supply Aux.

- 1 90-130V (2)
- 2 170-265V (2)
- 3 230-345V (2)
- 5 300-530V (2)
- 6 510-690V (2)
- 7 600-760V (2)

#### Fan Voltage

- 0 No fan < 120A
- 1 No fan 110V > 90A
- 2 No fan 220V > 90A standard version

#### Firing

- D Delayed triggering + burst firing DT+BF (3)
- P Phase angle PA
- E Soft start + phase angle S+PA

#### Manual

- 0 No manual
- 1 Italian
- 2 English
- 3 German
- 4 French

#### Version (5)

- 1 Std with fuse + fuse holder up to 40A
- 2 Second fuse normally used with phase to phase (4)
- E Second fuse with an additional safety electromechanical relay to open in alarm conditions (4)



(1) Available on units > 280A  
 (2) Load voltage must be included in selected auxiliary voltage range  
 (3) 8 cycles at 50% power demand  
 (4) This option is possible with unit up to 40A. Dimension equal relay M 2PH of same rating  
 (5) After final option, write current and voltage of load inside brackets Ex (190A-400V)





# WEST THYRISTORS

## Relay S - 1PH, 2PH & 3PH Thyristors

### Features

- Load type: normal resistance, infrared long and medium waveform
- Inputs: SSR Standard, 0-10V, 4-20mA and heater break alarm are options
- Firing mode: zero crossing, burst firing available with analogue input only
- Operating temperature: 0 to 40°C without derating
- Comply with EMC

Simple on/off firing with a DC logic input, time proportioned burst firing with a DC linear input (basic firing selectable between 4, 8 or 16 cycles). These simple units can be connected with Relay PC to manage multi-zone system.



### Selection Guide

Current		
030	30A	180 180A
035	35A	210 210A
040	40A	280 280A
060	60A	400 400A
090	90A	500 500A
120	120A	600 600A
150	150A	700 700A

Input	
S	SSR
V	0-10V DC
A	4-20mA

Control Mode	
O	Open Loop

### Fuse & Option

- O No Fuse for all units <= 40A
- F Fuse + fuse holder
- Y Fuse + fuse holder + CT
- H Fuse + fuse holder + CT + HB
- X Fuse + fuse holder + CT + HB with flat cable connection
- F Fixed fuses std for all units > 40A (6)
- Y Fixed fuses std + CT
- H Fixed fuses std + CT + HB

### Approvals

- O CE EMC for European market

### Model

- 1 1 PH
- 2 2 PH
- 3 3 PH

### Max Voltage

- 4 480V
- 6 600V
- 7 690V (1)

### Voltage Supply Aux.

- O No aux. voltage without HB & or analogue input up to 210A
- 4 With HB and/or analogue input on all unit <= 210A aux volt 12-24V AC-DC (2)
- 1 90-130V
- 2 170-265V (3)
- 3 230-345V (3)
- 5 300-530V (3)
- 6 510-690V (3)
- 7 600-760V (3)

### Firing

- Z ZC Zero crossing (4)
- 4 Burst firing 4 cycles on at 50% power demand (5)
- 8 Burst firing 8 cycles on at 50% power demand (5)
- 6 Burst firing 6 cycles on at 50% power demand (5)

### Fan Voltage

- O No fan < 120A
- 1 No fan 110V > 90A
- 2 No fan 220V > 90A standard version

### Manual

- O No manual
- 1 Italian
- 2 English
- 3 German
- 4 French

### Version

- 1 Std with one fuse only
- 2 Units with 2 fuses + fuse holder <= 40A (7)
- E Units with 2 fuses + fuse holder + Safety relay + fuse <= 40A (8)



(1) Available on units > 280A  
 (2) For all units > 210A with whichever options and inputs  
 (3) Load voltage must be included in selected auxiliary voltage range for units > 210A  
 (4) With 690V the firing is random  
 (5) Available only with analogue input  
 (6) Fixed fuses over 40A  
 (7) If you need one relay S 1PH with 2 fuse & fuse holder. For dimensions see relay S 2PH. This solution can be used up to 40A max.  
 (8) If you need one relay S 1PH with 2 fuse & fuse holder + safety relay. For dimensions see relay S 2PH. This solution can be used up to 40A max.



# WEST THYRISTORS

## Relay M - 1PH, 2PH & 3PH Thyristors

### Features

- Load type: normal resistance, infrared short, long and medium waveform and silicon carbide
- Inputs: 0:10V dc, 4:20mA, 10kpot, SSR, RS485
- Firing mode: zero crossing, burst firing, single cycle, soft start + phase angle and delayed triggering
- RS485 port. RTU Modbus protocol
- Operating temperature: 0 to 40°C without derating
- Control mode: voltage, Vxl power, I and I2
- Comply with EMC

Time proportioned burst firing with a DC linear input, front panel display and RS485 communications as standard.



### Selection Guide

Current			
035	35A	180	180A
040	40A	210	210A
060	60A	280	280A
090	90A	400	400A
120	120A	500	500A
150	150A	600	600A
		700	700A

Control Mode	
0	Open Loop
1	Voltage feed back
2	Power feed back
3	Current feed back
4	Voltage to power feed back transfer

Fuse & Option	
Y	For units <= 40A fuse + fuse holder + CT
H	Fuse + fuse holder + CT + HB with terminal
Y	For units > 40A fixed fuse std + C (4)
H	Fixed fuse std + CT + HB
A	Control mode retransmission 4-20mA
V	Control mode retransmission 0-10mV

Input	
S	SSR
V	0-10V DC
A	4-20mA

Approvals	
0	CE EMC for European market

Model	
1	1 PH
2	2 PH
3	3 PH

Max Voltage	
4	480V
6	600V
7	690V (1)

Voltage Supply Aux.	
1	90-130V (3)
2	170-265V (3)
3	230-345V (3)
5	300-530V (3)
6	510-690V (3)
7	600-760V (3)

Fan Voltage	
0	No fan < 120A
1	No fan 110V > 90A
2	No fan 220V > 90A standard version

Firing	
Z	ZC Zero crossing
C	Single cycle SC
B	Burst firing BF
J	Soft start + burst firing S+B
D	Delayed triggering + burst firing DT+BF
P	Phase angle PA
E	Soft start + phase angle S+PA

Manual	
0	No manual
1	Italian
2	English
3	German
4	French

Version	
1	Std with one fuse only
2	Units with 2 fuses + fuse holder <= 40A (5)
E	Units with 2 fuses + fuse holder + Safety relay + fuse <= 40A (6)

- (1) Available on units > 280A
- (2) For all units > 210A with whichever options and inputs
- (3) Load voltage must be included in selected auxiliary voltage range for units > 210A
- (4) Fixed fuses over 40A
- (5) If you need one relay S 1PH with 2 fuse + fuse holder. For dimensions see relay S 2PH. This solution can be used up to 40A max.
- (6) If you need one relay S 1PH with 2 fuse + fuse holder + safety relay. For dimensions see relay S 2PH. This solution can be used up to 40A max.





## WEST RAIL-MOUNTED DEVICES

### RailLine

#### Features

- 96 x 22.5 x 117.5mm format (HxWxD)
- Fieldbus couplers for Profibus, CAN, Modbus TCP, Modbus RTU and Ethernet IP - ensures cost-effective and convenient connections to PLC, IPC and operating terminals
- Bus monitoring
- Pre-defined output states in case of communication failure
- Compact design - modules only 22.5mm wide
- 3-key operation and multi-line LC display
- Plug-in terminals - no wiring to disconnect in case of module replacement
- Module replacement during operation (hot swap)
- BluePort® front port
- PC configuration tool BlueControl®
- Cost advantages during projecting, implementation and maintenance
- Local operation
- Freely configurable menu structure
- Freely selectable monitoring functions



Decentralised installations with fieldbus systems are finding increasing use in process and machine automation. In order to ensure reliable control in these allocations - also involving complex processes - modular components with additional functionality are required. The flexible RailLine system, WEST Control Solutions offers a comprehensive product portfolio for decentralised automation.

The combination of RL fieldbus couplers (for Profibus, CAN, Modbus TCP and Modbus RTU) with various I/O-modules, KS 45 universal controller, Uniflex CI 45 and the TB 45 temperature limiter, permits modular systems with distributed intelligence to be created.

The space-saving modules for rail mounting and other universally applicable system components help to save time and costs during system configuration, engineering and commissioning.



### KS 45 Process Controller

#### Features

- Display and operating functions
- Two universal inputs possible
- Timer and programmer
- Customised linearisation profile
- 2-point, 3-point, motor valve & continuous control
- Auto/manual switchover
- Fast sampling rate
- Universal output

The KS 45 process controller is a stand alone version for direct connection via RS485 Modbus or system version with buscoupler and inter-module connections permit additional controllers, transmitters and limiters to be fitted without wiring.

### CI 45 Universal Transmitter

#### Features

- Customised linearisation profile
- Correction of measurement value
- Slave pointer (min/max indicator)
- Two universal inputs possible
- Counter/frequency input, frequency output
- High resolution
- Fast sampling rate
- Universal output
- Two relay outputs

A universal transmitter, stand alone version for direct connection via RS485 Modbus or system version with buscoupler and inter-module connections permit additional controllers, transmitters and limiters to be fitted without wiring.

### RL 400 I/O Expansion Modules

#### Features

- RL400 offers a variety of sophisticated I/O modules
- High precision analogue inputs
- Output modules with fast on board signal processing
- Reinforced galvanic isolation
- Linearisation and measured value correction
- Up to 62 modules in a system
- Digital and analogue input & output modules:
  - Pt 100 in 2 or 4-wire connection - Thermocouples
  - Relays - Potential-free digital inputs
  - NPN/PNP inputs - mA/V

### TB 45 Temperature Limiter

#### Features

- 2 universal inputs possible, 2 relay outputs, analogue output
- Display and operating functions
- For all thermocouple types and resistive sensors
- Reset via key combination or external contact
- Type-tested to EN 14597 (replaces DIN 3440)

The TB 45 temperature monitor/limiter offers a stand alone version for direct connection via RS485 Modbus or system version with buscoupler and inter-module connections which permit additional controllers, transmitters and limiters to be fitted without wiring.





**W H Good Automation Ltd**

Carrs Industrial Estate  
Haslingden  
Rossendale  
Lancashire  
BB4 5JT

**Tel** 01706 216667  
**Email** [instruments@whgood.co.uk](mailto:instruments@whgood.co.uk)  
**Web** [whgood.co.uk](http://whgood.co.uk)